

Coping and Stools

An excerpt from the *Dimension Stone Design Manual*,
Version 7.2 (July 2011)



*Setting the Standards in the
Natural Stone Industry*

**Produced and Published by the
Marble Institute of America
28901 Clemens Road, Suite 100
Cleveland, Ohio 44145 U.S.A.
Telephone: 440-250-9222
Fax: 440-250-9223
www.marble-institute.com**

© 2011 Marble Institute of America

All rights reserved. No part of this document may be reproduced or transmitted in any form or by means electronic or mechanical, including photocopy, recording, or by an information storage and retrieval system, without written permission from the Marble Institute of America.

COPING and STOOLS - EXTERIOR CUBIC STONE COPING AND WALLS

1.0 INTRODUCTION

1.1 Installation Method. There are several methods by which cubic coping and walls can be installed. Consideration should be given to the various features of each method in making a selection for a specific installation. See information about installation methods in this section's Data Sheet, Part 3, and illustrations of examples at the close of this section.

2.0 DESIGN CRITERIA

2.1 Physical Property Values. Final design should always be based on specific physical property values for the stone to be used. These values may be obtained from the Stone Supplier.

2.2 Backup Walls. When exterior cubic stone is set in conjunction with masonry load-bearing walls, the masonry backup should be solid brick or concrete. If hollow load-bearing concrete block is used to support and anchor stone, it must be reinforced with brick, concrete, or by filling the voids full of concrete two block courses in each story height.

2.3 Bonding. It is recommended for exterior coping that there be 100% coverage of bonding material between the stone and the substrate.

2.4 Bond Stones. For cubic walls, the effectiveness of bonding is improved when bond stones are staggered at random. The number or percentage of bond stones depends on design; from 25% to 30% is generally sufficient. Bond stones should bear on floors and beams. Provide an open joint at intervals for expansion gasket.

2.5 Corrosion-Resistant Metals. All metals that contact the stone must be corrosive-resistant.

2.6 Oil-based putty and sealants should never be used in contact with stone.

2.7 White portland cement is recommended for light-colored granite and marble. White portland cement with a low alkali content is recommended for limestone.

For additional information, refer to Chapter 13, Installation General Information.

2.8 Geographic Methods. Some installation methods and materials are not recognized and may not be suitable in some geographic areas because of local trade practices, building codes, climatic conditions, or construction methods. Therefore, while every effort has been made to produce accurate guidelines, they should be used only with the independent approval of technically qualified persons.

DATA SHEET

EXTERIOR CUBIC STONE COPING AND WALLS

1.0 PRODUCT DESCRIPTION

1.1 Basic Use. Exterior masonry walls, caps, copings, and other cut stonework.

1.2 Fabrication. Exterior cubic stone units are precut and prefinished to dimensions specified on shop drawings, and are delivered to the job site ready to install.

1.3 Finishes. Abrasive, honed, and rough sawn finishes may be used for exterior cubic stone applications.

1.4 Colors. Most of the commercially available varieties are suitable.

2.0 TECHNICAL DATA

2.1 Each stone variety used for cubic stone coping and walls should conform to the applicable ASTM standard specification and the physical requirements contained therein. The specification for each stone type follows:

2.1.1 Granite: ASTM C615 Standard Specification for Granite Dimension Stone

2.1.2 Limestone: ASTM C568 Standard Specification for Limestone Dimension Stone

2.1.3 Marble: ASTM C503 Standard Specification for Marble Dimension Stone

2.1.4 Quartz-based Stone: ASTM C616 Standard Specification for Quartz-based Dimension Stone

2.1.5 Serpentine: ASTM C1526 Standard Specification for Serpentine Dimension Stone

2.1.6 Slate: ASTM C629 Standard Specification for Slate Dimension Stone

2.1.7 Soapstone: No ASTM Standard exists at this time

2.1.8 Travertine: ASTM C1527 Standard Specification for Travertine Dimension Stone

3.0 INSTALLATION

3.1 Preparatory Work. Exterior cubic stone may be installed against an existing backup or concurrently with the backup wall. It is recommended that the General Contractor install continuous flashing for stone coping.

3.1.1 When ready for installation, stones should be cleaned on all sides, and all dirt and foreign material removed from all surfaces.

3.2 Methods. Stones should be set in a full bed of mortar with the vertical joints full of mortar. Joints should be raked out to a depth equal to the width of joint, and later pointed or sealed with an approved, nonstaining sealant.

3.2.1 Expansion joints should be provided as required and kept free of mortar. Joint width may be maintained by using nonstaining, resilient cushions recessed 1" from exterior face. Joints should be at least 1-1/4" wide, except at control joints, where greater widths may be required.

3.2.2 All anchors, cramps, dowels, pins, supports, and similar items that contact the stone should be corrosion-resistant metals and should be securely attached to the structure and to the stone.

3.3 General Precaution. During construction, the General Contractor shall protect all stone from staining and damage.

3.3.1 Oil-based putty and sealants should never be used in contact with stone.

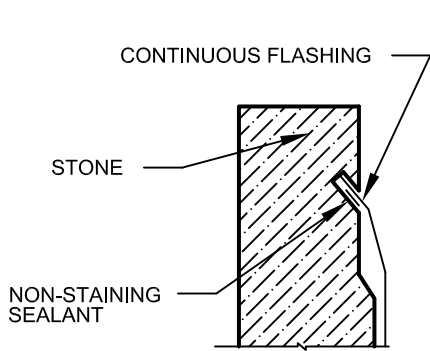

1 PARAPET DETAIL

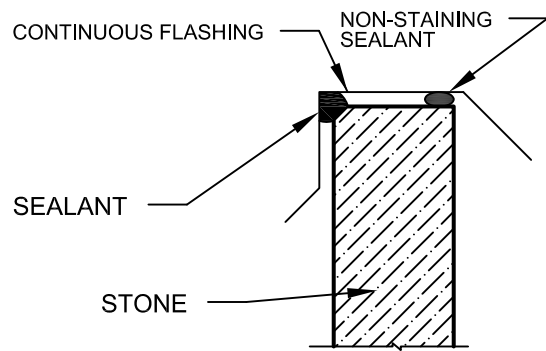

2 PARAPET DETAIL

NOTE: MINIMUM RECOMMENDED STONE THICKNESS FOR THESE DETAILS IS 1-1/4".

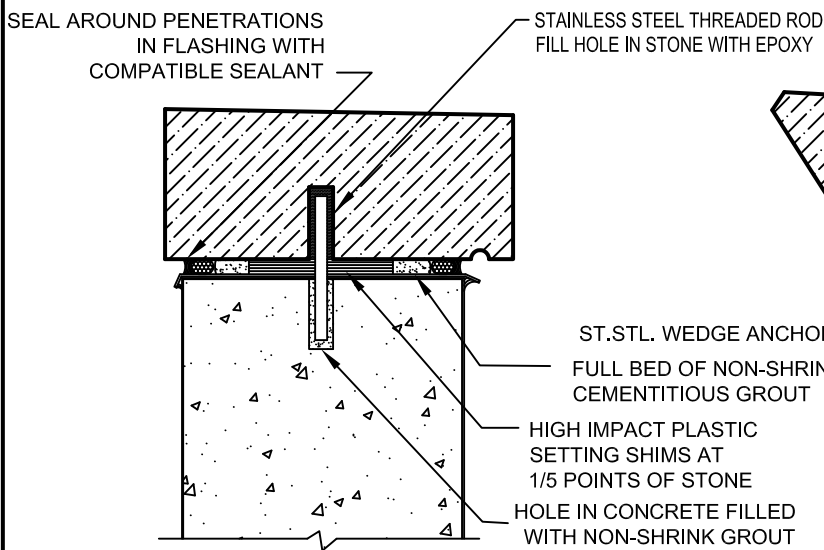

3 COPING DETAIL

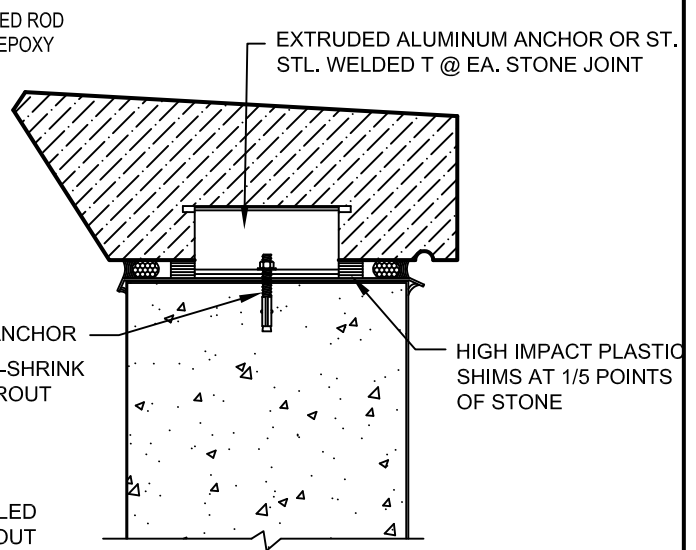

4 COPING DETAIL

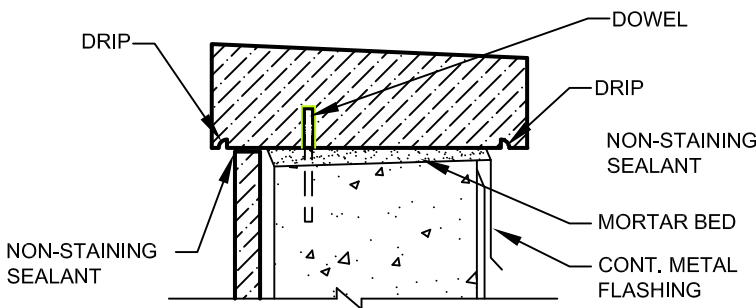

5 COPING DETAIL

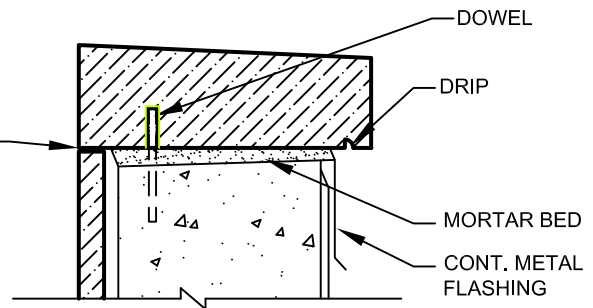

6 COPING DETAIL



MARBLE INSTITUTE of AMERICA
 28901 Clemens Road - Suite 100
 Cleveland, OH 44145
 Tel: (440) 250-9222
 Fax: (440) 250-9223
 www.marble-institute.com

REV	DATE
0	Aug 2006
1	Oct 2006

EXTERIOR STONE VENEER FLASHING & COPING DETAILS

MIA DIMENSION STONE DESIGN MANUAL VII

DRWG NO: 18-D-1

SCALE:
3" = 1'-0"

NOTES:

COPING and STOOLS - THIN STONE STOOLS AND CUBIC SILLS

1.0 INTRODUCTION

1.1 Installation Methods. There are several methods by which stone window stools can be installed. Consideration should be given to the various features of each method in making a selection for a specific installation. See information about installation methods in this section's Data Sheet, Part 3, and illustrations of examples at the close of this section.

2.0 DESIGN CRITERIA

2.1 Oil-based putty or sealants should never be used in contact with stone.

2.2 Corrosion-resistant Metals. All metals that contact the stone must be corrosive-resistant.

2.3 Bonding. There must be 100% coverage of bonding material between stone window stools and substrate.

2.4 White portland cement is recommended for light-colored granite and marble. White portland cement with a low alkali content is recommended for limestone.

For additional information, refer to Chapter 13, Installation General Information.

2.5 Geographic Methods. Some installation methods and materials are not recognized and may not be suitable in some geographic areas because of local trade practices, building codes, climatic conditions, or construction methods. Therefore, while every effort has been made to produce accurate guidelines, they should be used only with the independent approval of technically qualified persons.

DATA SHEET

THIN STONE STOOLS AND CUBIC SILLS

1.0 PRODUCT DESCRIPTION

1.1 Basic Use. Interior window stools and exterior cubic sills.

1.2 Fabrication. Stone window stools and cubic sills are precut and prefinished to dimensions specified on shop drawings, and are delivered to the job site ready to install.

1.3 Finishes. Exposed surface and edges of thin stone stools shall be polished or honed. Cubic sills shall be abrasive, honed, or rough finish.

1.4 Colors. Most of the commercially available varieties are suitable.

1.5 Sizes. Thin stone stools shall have thicknesses of $\frac{3}{4}$ " and $1\frac{1}{4}$ ", or as specified. Cubic sills shall be as specified.

2.0 TECHNICAL DATA

2.1 Each stone variety used for thin stone stools and cubic sills should conform to the applicable ASTM standard specification and the physical requirements contained therein. The specification for each stone type follows:

2.1.1 Granite: ASTM C615 Standard Specification for Granite Dimension Stone

2.1.2 Limestone: ASTM C568 Standard Specification for Limestone Dimension Stone

2.1.3 Marble: ASTM C503 Standard Specification for Marble Dimension Stone

2.1.4 Quartz-based Stone: ASTM C616 Standard Specification for Quartz-based Dimension Stone

2.1.5 Serpentine: ASTM C1526 Standard Specification for Serpentine Dimension Stone

2.1.6 Slate: ASTM C629 Standard Specification for Slate Dimension Stone

2.1.7 Soapstone: No ASTM Standard exists at this time

2.1.8 Travertine: ASTM C1527 Standard Specification for Travertine Dimension Stone

3.0 INSTALLATION

3.1 Methods: Stone window stools are installed either by the standard or thin set method. Cubic sills are installed in a full portland cement mortar bed with dowels.

3.2 General Precautions: During construction, the General Contractor shall protect all stone from staining and damage.

3.2.1 Oil-based putty and sealants should never be used in contact with the stone.

NOTES:

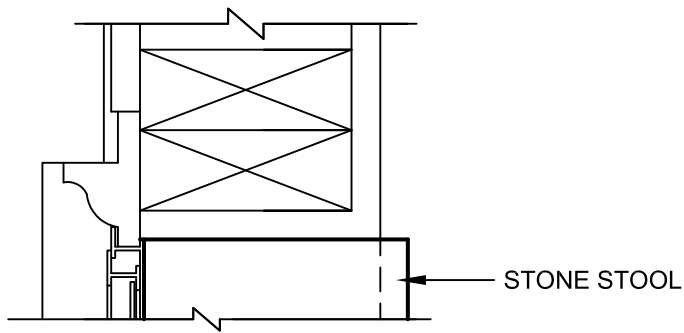

1 PLAN SECTION
(WOOD FRAME CONSTRUCTION)

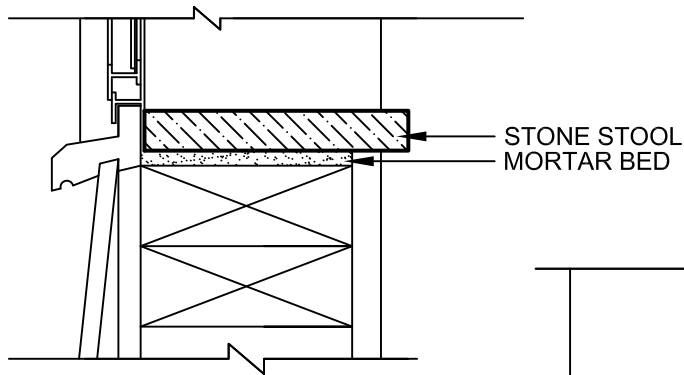

2 SECTION
(WOOD FRAME CONSTRUCTION)

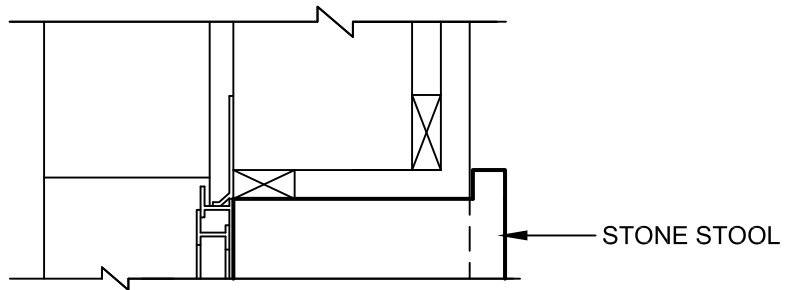

3 PLAN SECTION
(MASONRY CONSTRUCTION)

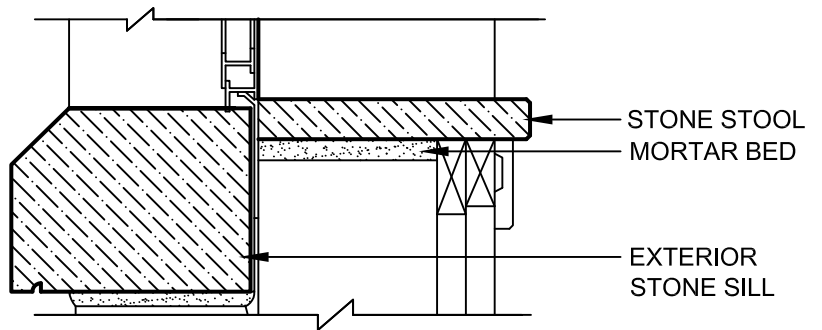

4 SECTION
(MASONRY CONSTRUCTION)

NOTE: USE 100% COVERAGE OF MORTAR BED MATERIAL BETWEEN STOOL AND SUBSTRATE.



MARBLE INSTITUTE of AMERICA
28901 Clemens Road - Suite 100
Cleveland, OH 44145
Tel: (440) 250-9222
Fax: (440) 250-9223
www.marble-institute.com

REV	DATE
0	Aug 2006
1	Oct 2006

THIN STONE STOOLS AND CUBIC SILLS-WINDOW STOOL DETAILS

MIA DIMENSION STONE DESIGN MANUAL VII

DRWG NO: 18-D-2

SCALE:
3" = 1'-0"